

TECHNICAL RIDER

The Leif de Leeuw band will use the club's sound- and light technicians.

STAGE PLOT

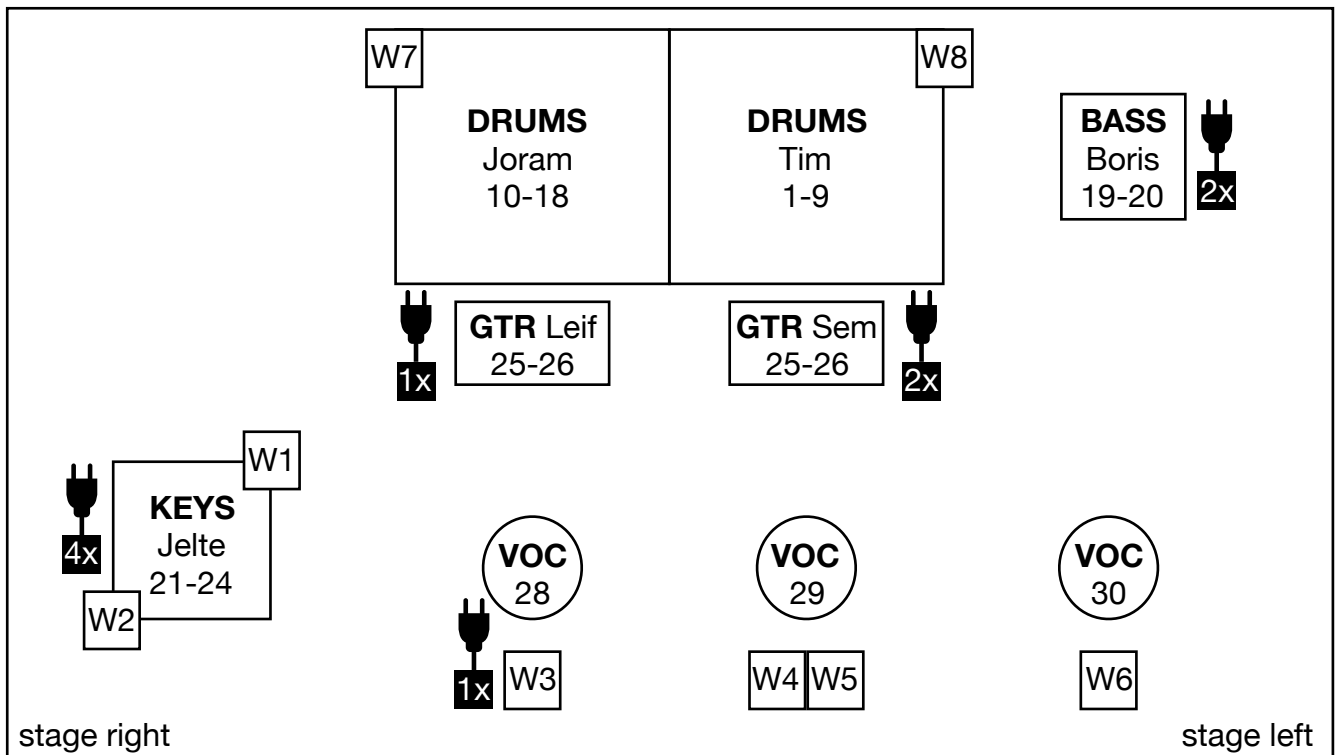

REQUIREMENTS ON STAGE

- Drum risers:
We need two drum-risers. We can either use one big drum riser or two separate risers put together. The minimal measurements needed are 4x2 meters for the combined riser. The drummers will both use their own carpets on the drum-risers.
- Banners:
We use 3 banners. Two with the measurements: 1.70x2.40 meters and one with the measurement: 2.40x2.40 meters. These will be attached with tie-wraps we bring ourselves. If there is no automatic truss system we would like the venue to provide us with a ladder. Depending on the measurements of the stage and venue we will use one, two or all three of them.
- Carpets:
We bring two big Persian carpets and would like the front of the stage to be as empty as possible for us to lay them down when we arrive.
- We prefer to first put our gear on stage and make sure everything is ready to go and then leave the stage and have the sound engineer mic everything.

Channel#	Instrument	Mic/DI	
1	KickTIM	Audix D-6	
2	SnTopTIM	Shure SM-57	
3	SnBotTIM	Sennheiser E604	Optional
4	Rack1TIM	Sennheiser E604	
5	Rack2TIM	Sennheiser E604	Optional
6	FloorTIM	Sennheiser E604	
7	HhTIM	KM184	
8	OverheadLeftTIM	AKG214	Optional
9	OverheadRightTIM	AKG214	
10	KickJORAM	Audix D-6	
11	SnTopJORAM	Shure SM-57	
12	SnBotJORAM	Sennheiser E604	Optional
13	Rack1JORAM	Sennheiser E604	
14	Rack2JORAM	Sennheiser E604	Optional
15	FloorJORAM	Sennheiser E604	
16	HihatJORAM	KM184	
17	OverheadLeftJORAM	AKG214	
18	OverheadRightJORAM	AKG214	Optional
19	BassDI	DI	Direct DI- out on amp
20	BassAMP	MD421	Optional
21	Keys1L	DI	Keys need 4 single DI's or 2 stereo DI's
22	Keys1R	DI	
23	Keys2L	DI	
24	Keys2R	DI	
25	GuitarLEIF1	Shure SM-57	Will use a plexi screen
26	GuitarLEIF2	E906	Optional, will be discussed before gig.
27	GuitarSEM	Shure SM-57	Will use a plexi screen
28	VocLEIF	Shure SM-58(Beta)	Presentation
29	VocSEM	Shure SM-58	Lead vocals, uses own microphone, would like a stand and clip.
30	VocBORIS	Shure SM-58(Beta)	Backing vocals

WEDGES

We would like to use 8 wedges on 6 different groups. If the venue is not able to provide this please contact us on beforehand so we can come to a solution together.

We don't have set wedge preferences since every room asks for different settings, therefore we would like to start the soundcheck with blank wedges and add whatever we need during the soundcheck.

Wedge	Instrument	Name	
W1	Keys	Jelte	Keys:Left - rest double mono
W2	Keys	Jelte	Keys:Right - rest double mono
W3	Leadguitar	Leif	
W4	Leadvocals/guitar	Sem	
W5	Leadvocals/guitar	Sem	
W6	Bass/Backing	Boris	
W7	Drums stageright	Joram	
W8	Drums stageleft	Tim	

Note: We sometimes change gear or musicians, we try to keep our rider as up to date as possible but last minute changes may occur. If this would be a problem please let us know on beforehand so we can inform you about what changes we have as soon as possible.

LIGHT

If the engineer wants to use strobe lights please discuss it with the band on beforehand. We have no issues with the use of smoke-machines.

MERCHANDISE

To sell our merchandise we need the venue to provide us with a table/bar (minimum length 2 meters) with a chair/barstool. We will discuss the position of the merchandise stand at arrival.

CONTACT:

Bookings/tourmanagement:

Arja Stam +31 6 531 55 260

arja@ddaagency.nl

Technical contact:

Leif de Leeuw +31 6 102 34 433

leifdeleeuw@gmail.com

Sem Jansen +31 6 404 07 909

semjansen1992@gmail.com